

BALL BEARING HINGE SPECIFICATION

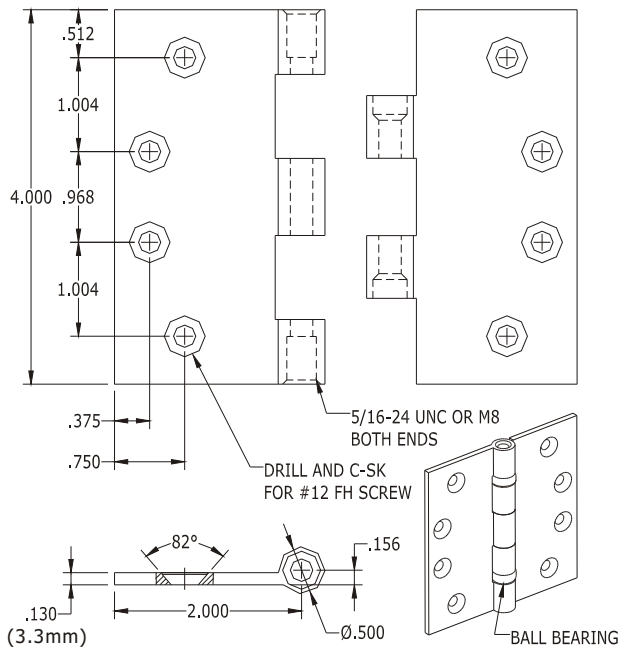

4×4×.130 (3.3mm) INCH SQ HINGE WITH BALL BEARING
WEIGHT: 0.766LB (347g)

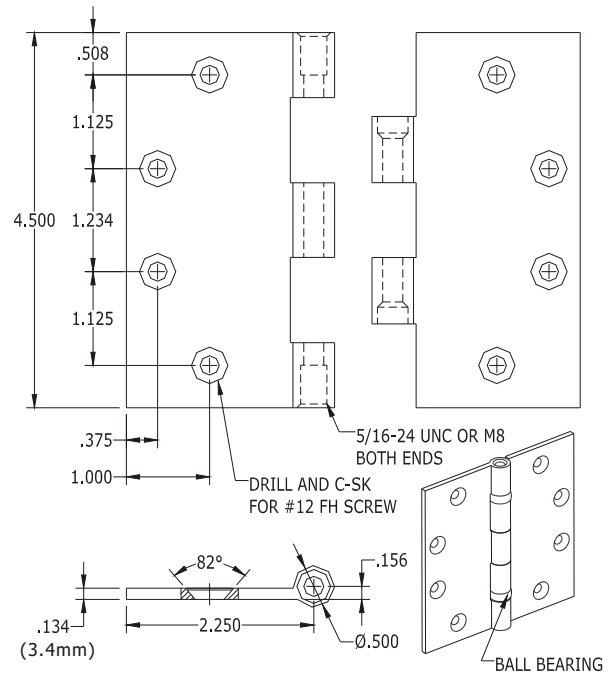

4.5×4.5×.134 (3.4mm) INCH SQ HINGE WITH BALL BEARING
WEIGHT: 0.957LB (434g)

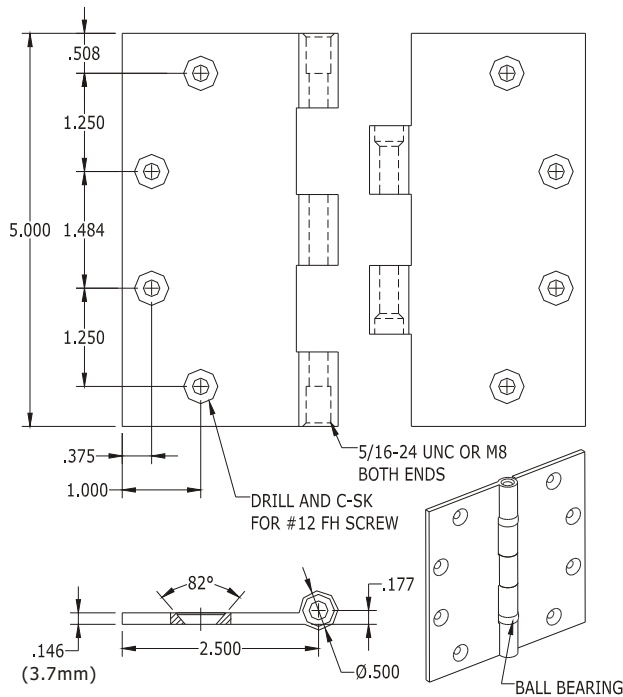

5×5×.146 (3.7mm) INCH SQ HINGE WITH BALL BEARING
WEIGHT: 1.239LB (562g)

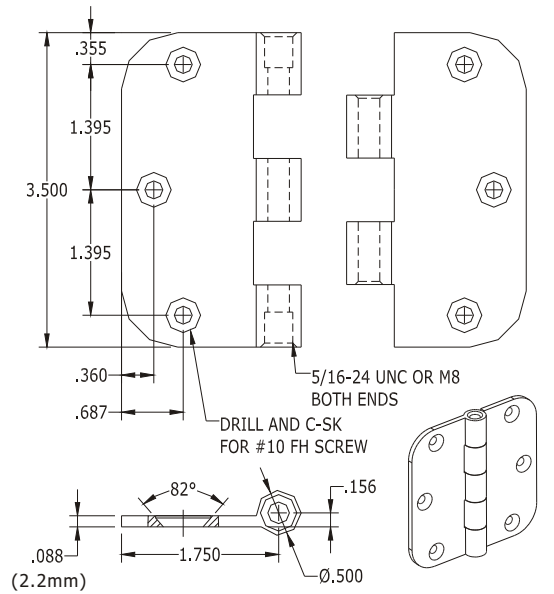

3.5×3.5×.088 (2.2mm) INCH RADIUS CORNER HINGE
WEIGHT: 0.445LB (202g)

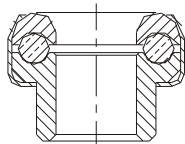

BALL BEARING (CHROME PLATED, HARDENED HIGH CARBON STEEL)

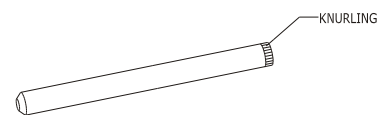

PIN (STAINLESS STEEL)